

The **WITHERING WIZARD**TM

The world's first & most advanced
Automated Continuous Withering System

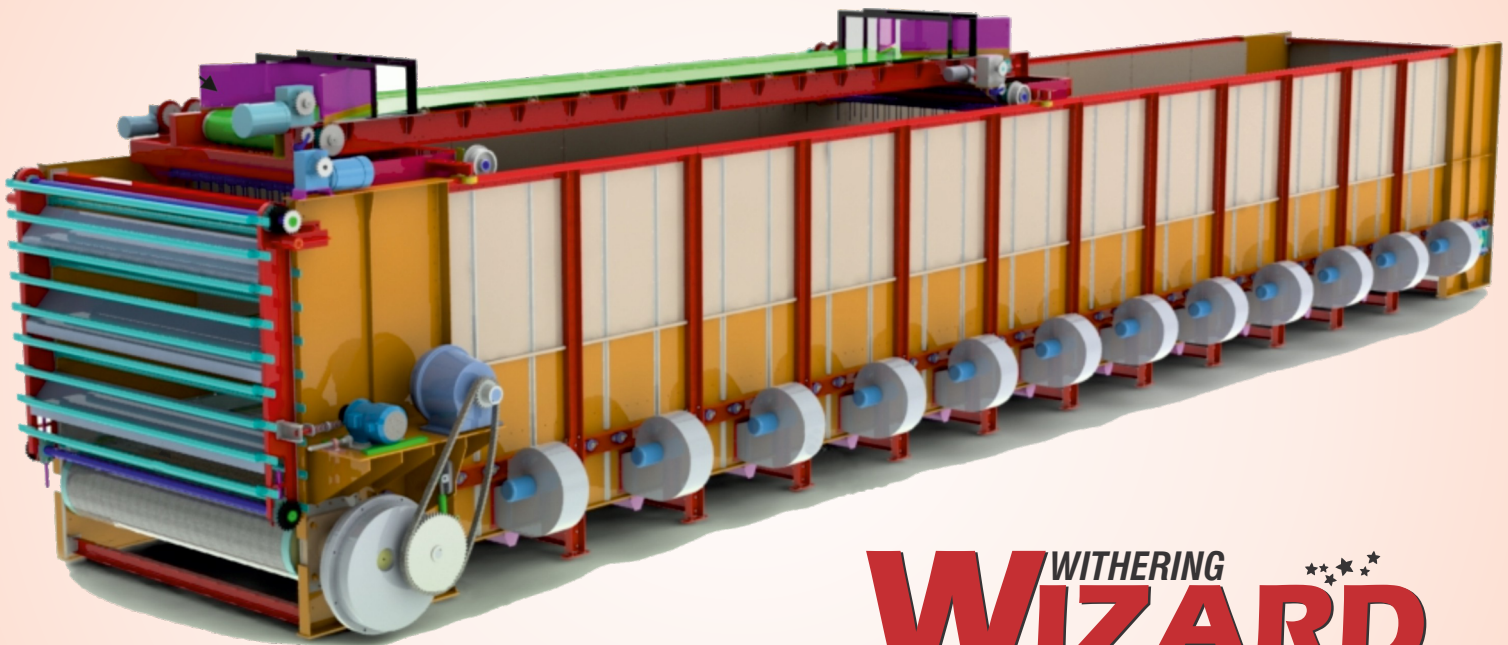

WITHERING WIZARDTM
CONTINUOUS WITHERING MACHINE



**The innovative
new launch from TIG**



Range of Withering Machines

THE WORLD'S FIRST & MOST ADVANCED AUTOMATED CONTINUOUS WITHERING SYSTEM

WIZARD Automatic Continuous Withering Machine has transformed traditional Withering practices.

WIZARD converts batch process of Tea to continuous process by incorporating Chemical and Physical Withering in two stages.

The machines have conveyerised Leaf Feed and Leaf discharge arrangement.

SALIENT FEATURES

- Area needed is 50% less compared to troughs
- Power requirement half of conventional method
- Low cost of withering
- Consistent wither percentages in spite of varying ambient conditions
- Leaf damage and wastage totally eliminated.
- Labour cost and involvement almost zero

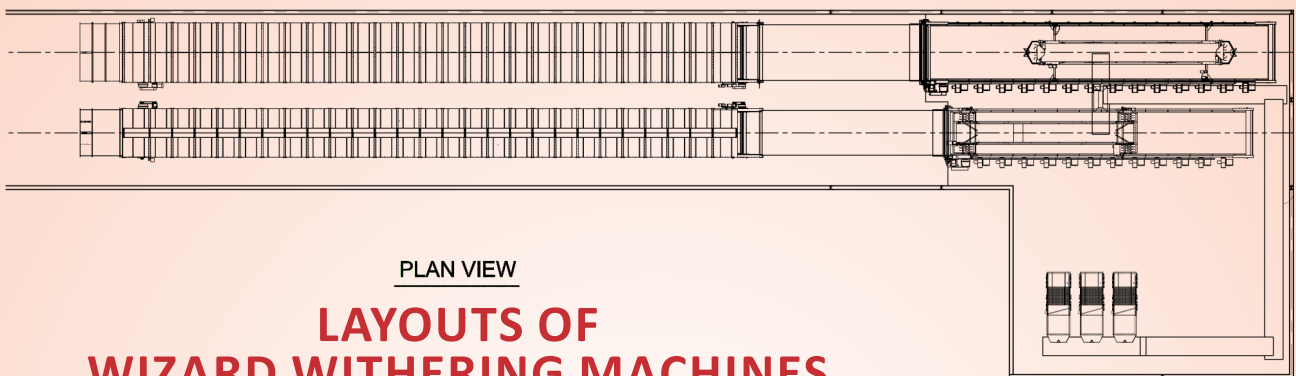

PLAN VIEW

LAYOUTS OF WIZARD WITHERING MACHINES

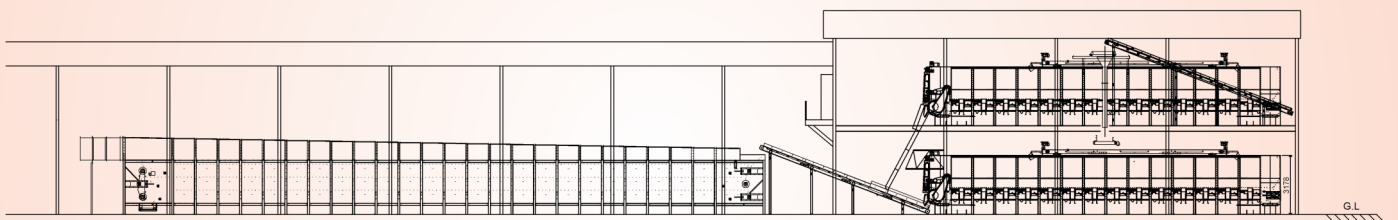

ELEVATION

- Consistent Withering
- 60% Power Savings
- Just 5 Workers for 30000 kgs/G.L.
- Covers only 30% Footprint Area

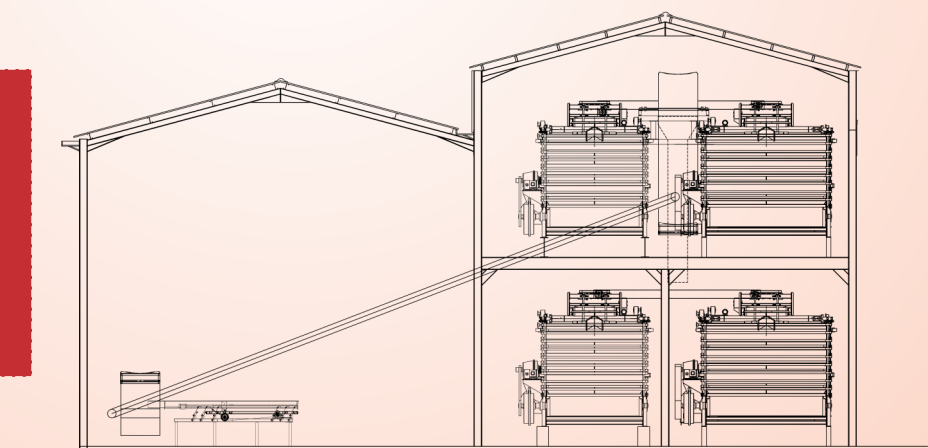



ADVANTAGES OF WIZARD

DESCRIPTION	CONVENTIONAL TROUGHS	THE WIZARD
Quality of withering	Sometimes uneven withering	Always constant withering
Space	Standard area	1/3 of standard area
Building construction	Heavy and expensive	Light and much less expensive
Power	Standard units	40% of standard units
Labour	Standard requirement	15% of standard requirement
Spreading	Manual	Automatic
Shuffling	Manual	Automatic
Spillage	Large	None
Leaf damage/wastage	Yes	Nil
Supervision and control	Multi station and difficult	Single point and easy
Quality of tea	Inconsistent	Absolutely consistent
Maintenance	Constant and expensive	Periodic and less expensive
Feed & Discharge	Manual	Conveyorized

LAYOUT OF CONVENTIONAL WITHERING TROUGHS

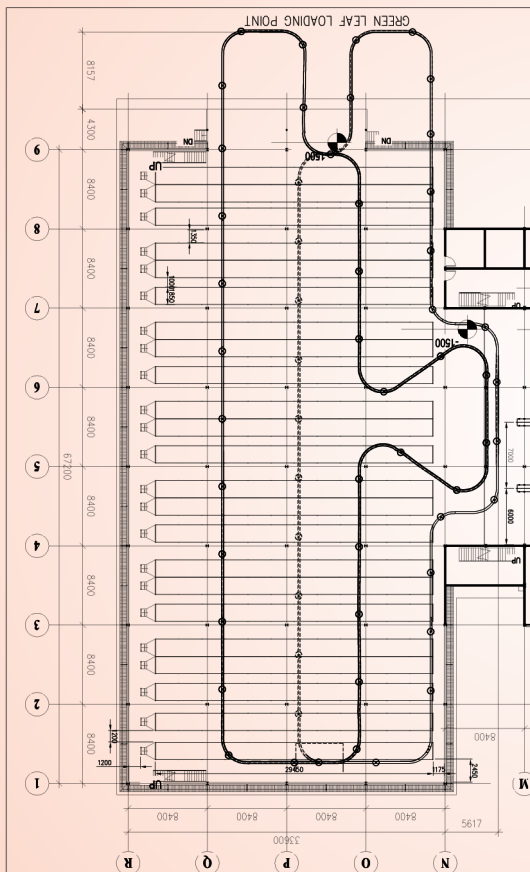

LAYOUT WITH WIZARD WITHERING MACHINES

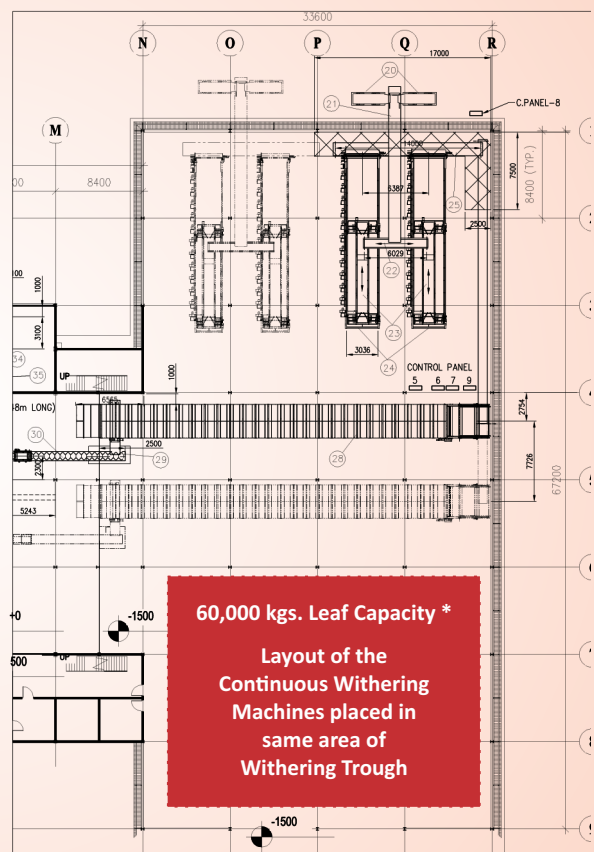

* Capacity will vary depending on leaf quantity, ambient condition etc

Delighted users of WIZARD

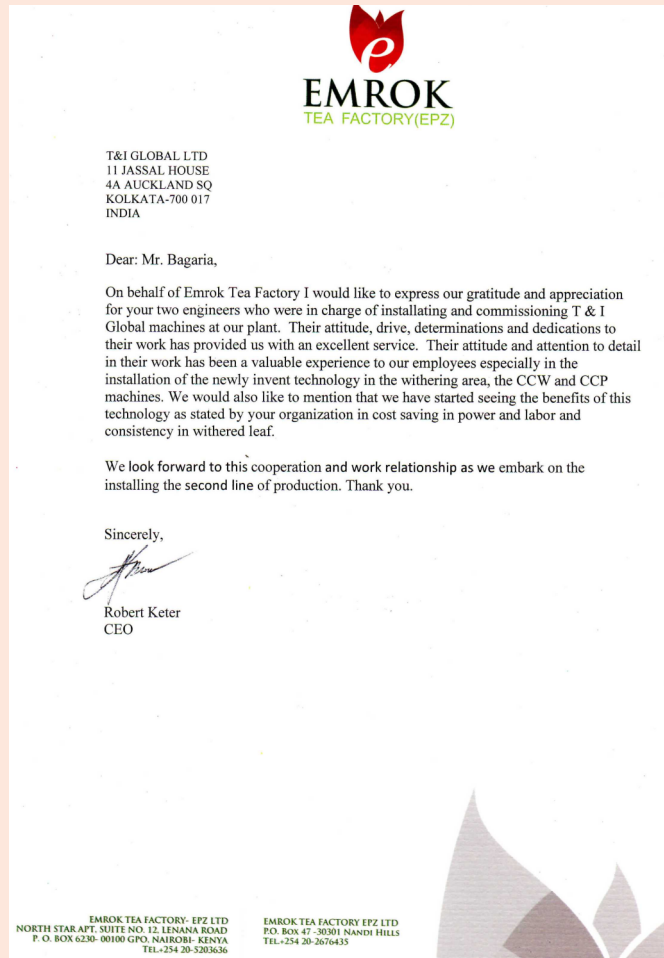
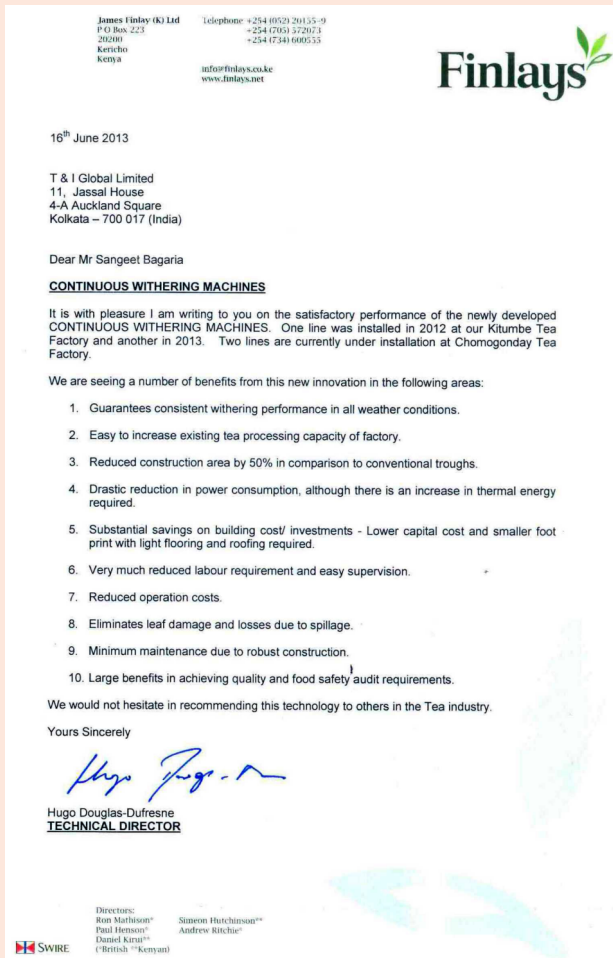

Avail of T & I Global's **Turnkey Solutions** for tea processing - an innovative and custom engineered range of machinery and factory solutions.

TURNKEY SERVICES	SPARES & SERVICE AT YOUR DOORSTEP	
<ul style="list-style-type: none"> • Factory Planning & Layout • Structural & Civil Works execution with channel partners • Supply of customised tea processing line for CTC, Orthodox & Green Tea 	<ul style="list-style-type: none"> • Genuine Guaranteed OEM Spares & Prompt Delivery • Installation & Maintenance • Troubleshooting & Breakdown • AMCs & Technical Support • Overhauling & Reconditioning • Automation & Factory Layouts 	